

MecSoft Corporation

18019, Sky Park Circle, Suite K-L
Irvine, CA 92614, USA

PHONE: (949) 654-8163
FAX: (949) 654-8164
E-MAIL: sales@mecsoft.com
www.mecsoft.com

What's New In RhinoCAM 2.0

Major New Enhancements

- New advanced 3 Axis toolpath methods such as 3-D Offset pocketing and 3-D Offset profiling have been introduced
- High speed machining transitions have been introduced in 3 Axis finishing methods
- Shop Documentation. Users can now create HTML based shop documentation from inside RhinoCAM part files.
- Features on 3D part can be selected as machining geometry without having to explicitly create curves. This increases productivity for 2-1/2 axis machining operations significantly
- All 3 Axis toolpath methods now machine only visible geometry. Users can turn off the visibility of geometry using the layer manager if it is desired to exclude them from being considered during toolpath computations

User-Interface Enhancements

- Fresh new look
- New interface for the browser. This is shown below:

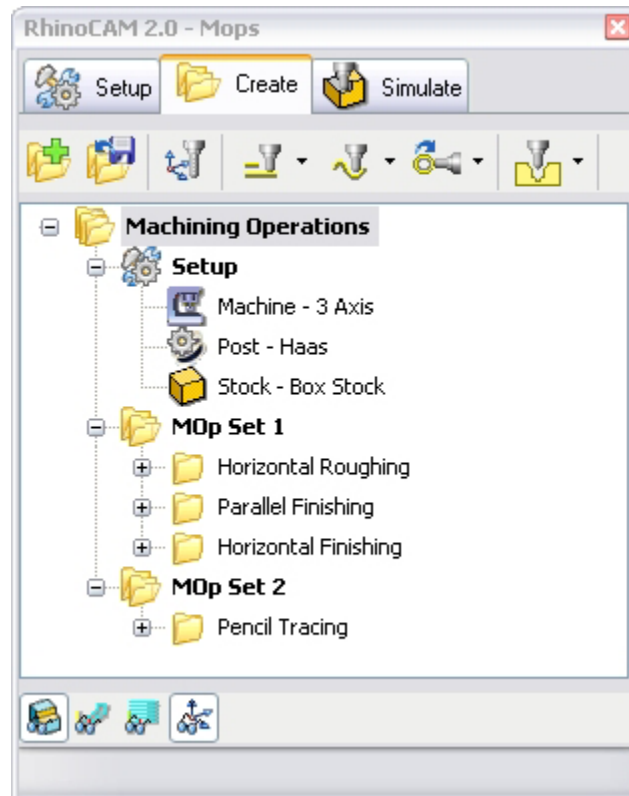

- Setup, Create, and Simulate. Tabs can be docked and rearranged independently for more efficiency and control

Machining Operations

- Machining geometry, Tool and parameters can be selected inside a machining operation decreasing button pokes and increasing productivity.
- Flat area features from the 3D model can be selected as machining features
- Improved region selection tools
- Tool geometry information can be viewed inside of machining operations

Tool Enhancements

- Select Tools from Library (Drag -n- Drop tools from a library)
- New tool type entries for V-Bits, Chamfer tool and Taper tools.
- Tool preview in the graphics viewport after creating/editing a tool
- Feeds/Speed can be set to tool or can be loaded from table.
- Load Feeds/Speeds can be launched inside of Set Feeds/Speeds.

Stock Enhancements

- Stock geometry can be displayed with the part model.
- Stock transparency of stock models can be varied as shown below

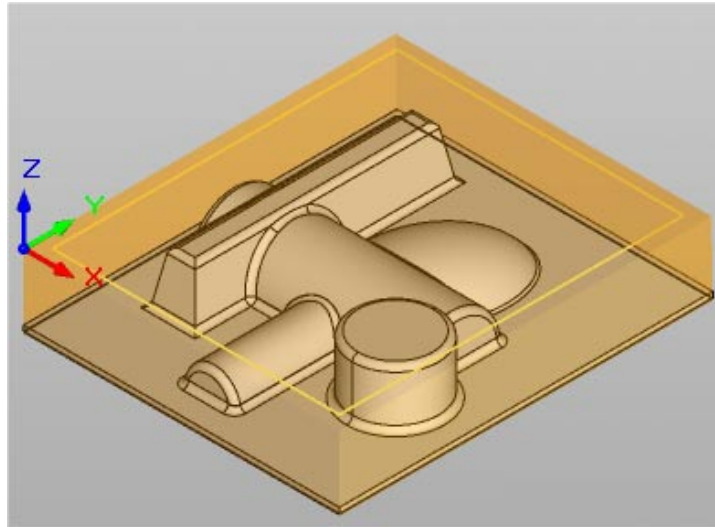

2-1/2 Axis Methods Enhancements

- New V Carve Roughing method where a roughing cutter automatically compensates for V-carve tapered bit has been introduced.

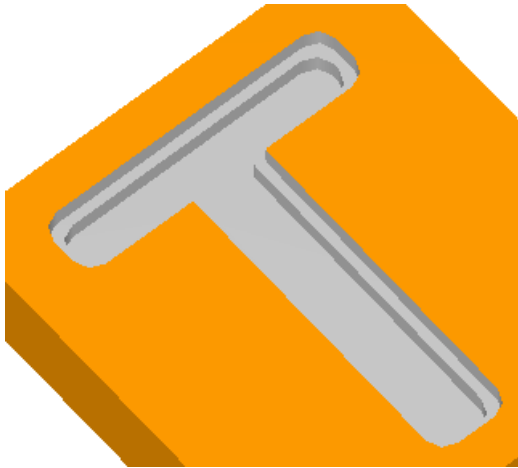

- New V Carving method separated out of Engraving

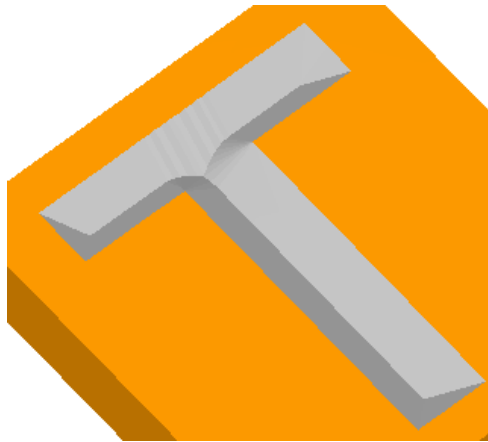

- New Chamfering method has been introduced

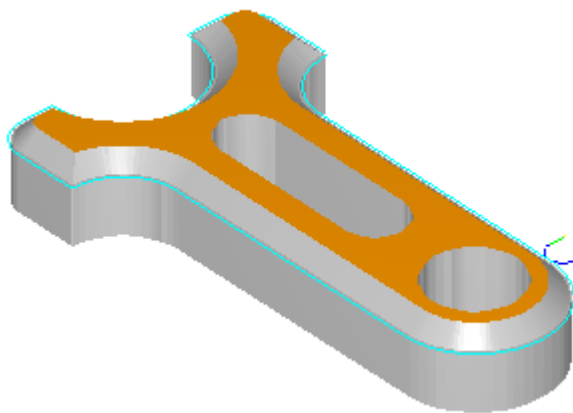

- Engraving method has been simplified
- Sorting features for 2.5 axis Profiling & Hole Pocketing
- Facing toolpaths have been enhanced to maximize material removal.
- Facing entry/exits have been consolidated and streamlined
- Pocketing entry/exits have been consolidated and streamlined. New 3D ramp exit method has been added.

- Now it is possible to create Tabs / Bridges for 2.5 axis Profile operations. This is shown below:

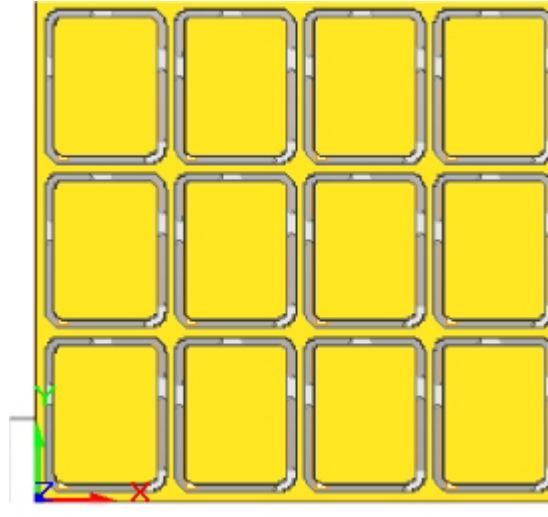

- Along path 3D Entry for Profiling has been introduced. This is shown below:

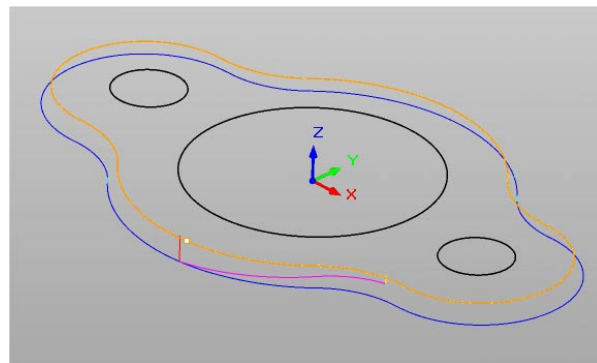

New 3 axis Machining Methods

The following new machining methods have been introduced:

- A new 3D Offset profiling method introduced. This method uses a curve and creates toolpaths by offsetting the curve in such a way that the offsets are equidistant to each other on the part surfaces below. This results in a constant scallop height of material left on the machined part.

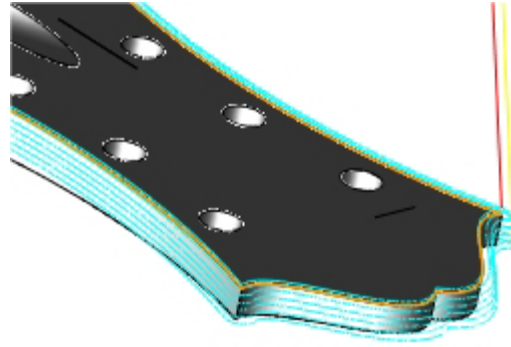

- A new 3D Offset pocketing method introduced. This method uses a closed curve and creates constant offset toolpaths on the part surfaces below.

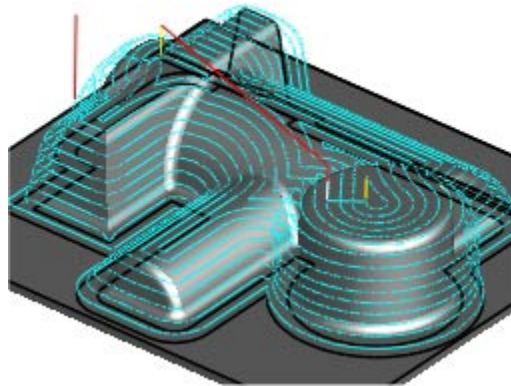

- Multiple Passes for Pencil Tracing. The single pencil trace toolpaths are offset outward using a constant offset distance on the part surfaces below. This method is very efficient for roughing out valleys and corners in hard materials. It can also be used as a finishing method.

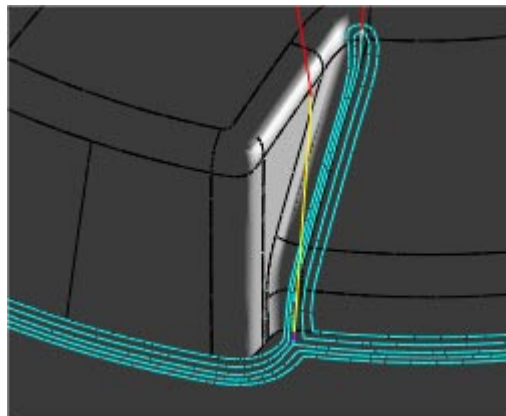

- Split Cuts, step over and cut control for Valley Re-Machining. Finishing areas where a larger cutter left material has been enhanced to allow for the following types of cut patterns:

- Along
- Across
- Horizontal
- Parallel

In addition to this these cut patterns can be applied independently after the original valley re-machining cuts are separated out as steep and shallow cuts.

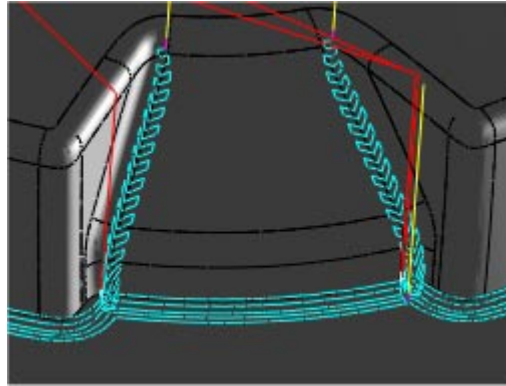

3 Axis Enhancements

- Spiral and Radial Machining have been introduced in the entry level RhinoCAM 2.0 product
- New Z containment for Parallel finishing, Radial and Spiral Machining
- Multiple step-down cuts for Parallel finishing, Radial and Spiral Machining

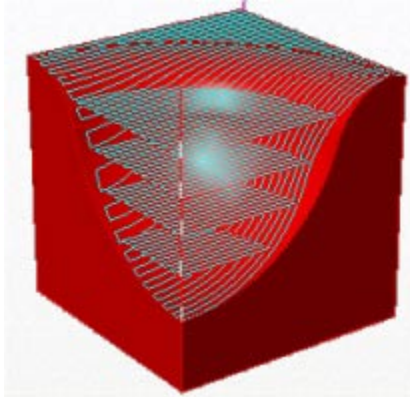

- Straight, linear, Radial cut connections with high-speed loops between cut connections for all finishing methods has been introduced

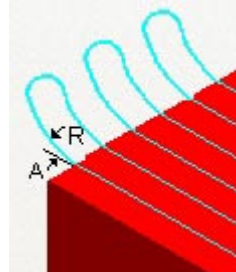

- Along path 3D Entry for 3 axis Horizontal Finishing

New 3 axis Machining Region Methods

New methods to create machining regions based on the part geometry and the cutting tool have been introduced. These methods are as follows:

- Flat Area Regions. This method creates the cutter center-line curves that will machine areas defined by a lower and higher angle value. This is shown below for an angle between 0 and 1 degree.

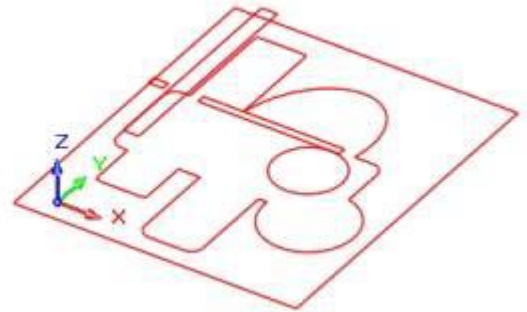
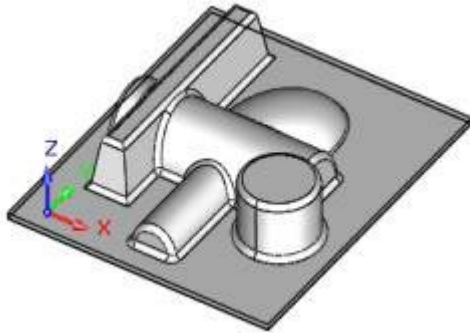

- Tool Silhouette Area Regions. This method creates cutter center-line curves that will machine a set of surfaces completely such that the tool contacts extend all the way to the edges of the surface. An example is shown below:

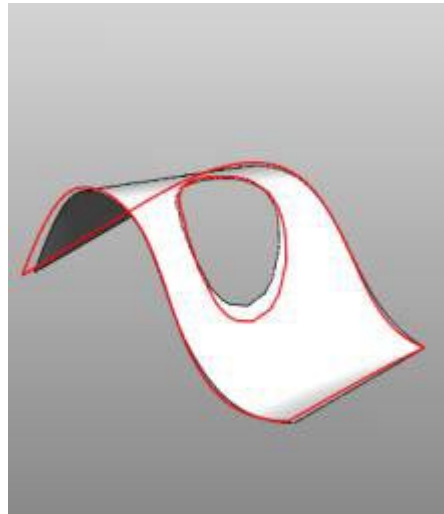

- Tool Double Contact Area Regions. This method creates curves that represent the contact points of a cutter in areas where there are double contacts for the cutter. This is shown below:

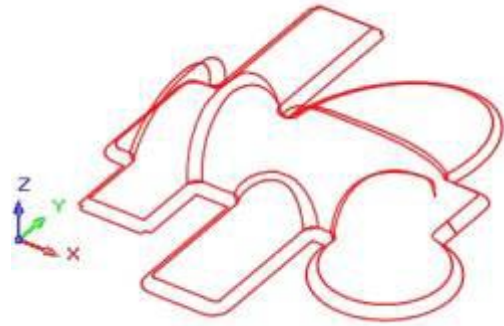
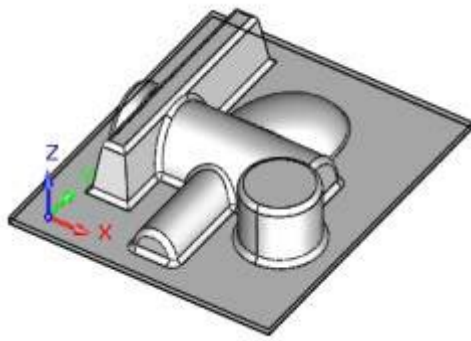

- Check Surface Regions. This method determines the regions where the tool can machine only a specific surface or set of surfaces. The system will compute the regions in such a way that the tool can traverse machine the selected surfaces.

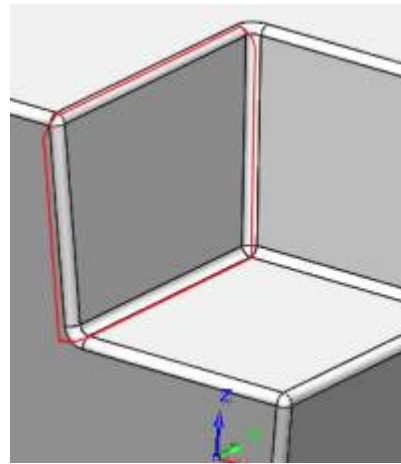
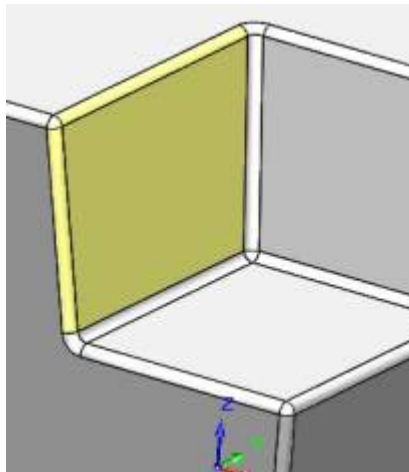

- Tool Holder Collision Regions. Determine areas in the part that have potential tool holder collisions and create these areas as curves.

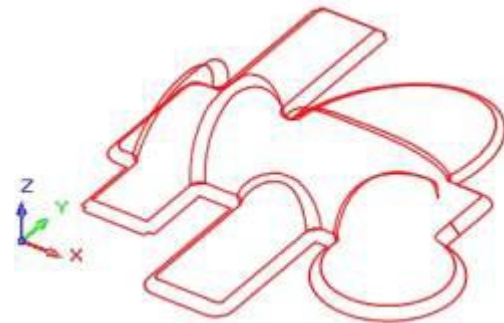
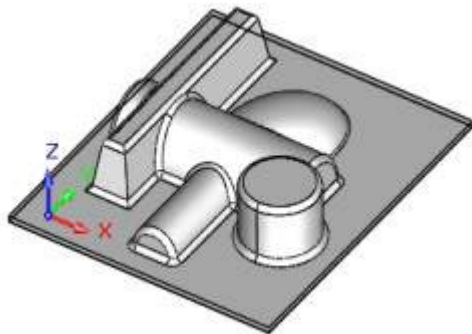

- Detect Tool Holder Collisions Areas* - Determine tool holder collisions with part geometry for the selected tool and display color-coded areas depending on amount of collisions.

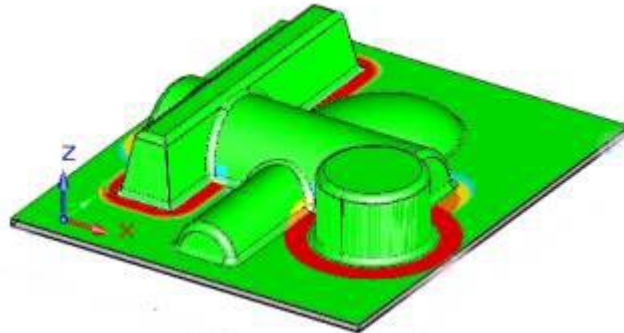

4 Axis Enhancements

- 4 Axis Table Rotation Operation has been enhanced to implement incremental and auto-multiple rotations. This allows rotational instancing of toolpaths without having to reprogram all instances.
- 4 Axis Facing Method has been added
- 4 Axis Pocketing Method has been added
- 4 Axis Profiling Method has been added



4 Axis Facing

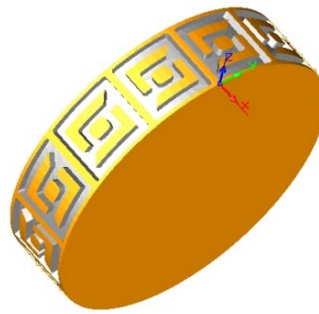

4 Axis Pocketing

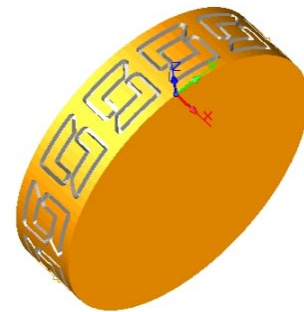

4 Axis Profiling

- 4 Axis Hole making methods such as drilling, tapping, boring and reverse boring have been added.
- 4 Axis Multiple Level finishing has been separated out as a separate Roughing operation

Post-processor Features

- Post Processor setup and post processing made easier.
- Additional posts have been introduced.
- Fixture Offset programming has been introduced
- 5 Axis angle output enhancements
- Enhancements to arc format output

Knowledge Base Enhancements

Multiple Knowledge bases can now be loaded without overwriting existing Mops information.

Fixture Offset Programming

Users can specify fixture offsets when multiple instances are necessary to be machined using the SetMCS dialog shown below.

Align MCS With | Set MCS Origin | **Set Fixture Offsets**

Output Fixture Offsets

Register Start Number: 54

Operation Repeat Count: 0

Register Number Increment: 1

DNC

- New version of one port DNC from Multi-DNC corporation included with the software
- Toolpath analyzer and g-code editor has been updated

Miscellaneous

- Extensive new tutorials have been created for RhinoCAM 2.0
- On-line help has been revised completely